

Stabligh "A" - Aquamarine

Arik Levy

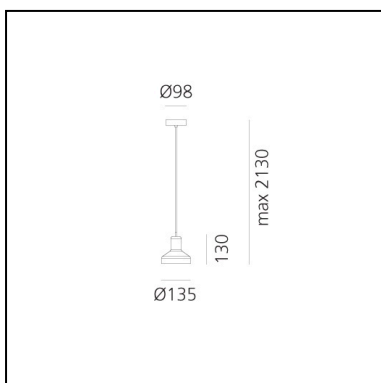

IP20   



LUMINAIRE *

- Watt: **5,5W**
- Delivered lumen output: **340lm**
- Efficiency: **97%**
- Efficacy: **67.90lm/W**

* **CRi 90** data may vary depending on the source installed.
Light measurements are provided in relative form and technical lighting calculations may be updated according to the effective source used.

DESCRIPTION

The Stab light are produced with very traditional bohemian handblowing technology. Its handblowing to wooden moulds. The moulds are produced by hand as well, from hard and wet wood. The glass masters are using glass blowing pipe as basic instrument, gathering several layers of glass in various colors and by mouth blowing and shaping with hand tools prepares shape which is very close to the moulds shape. In final stage the glass masters puts the pre-shaped hot glass into the mould and finish the piece to the final shape, which is given by exact form of the mould. After the "hotshop" production phase the vases are finished on cutting shop, where additional parts are cutted out and surface is polished to high gloss. This production process stays on extraordinary skills of glass masters, who are passing their experience from generation to generation.

FEATURES

- Product Code: **DAL0027M14**
- Colour: **Aquamarine**
- Installation: **Suspension**
- Material: **blown glass, metal**
- Series: **Design Collection**
- Environment: **Indoor**
- design by: **Arik Levy**

DIMENSIONS

- Height: **130 mm**
- Diameter: **98 mm**
- Base Diameter: **100 mm**
- Max Extension Height: **2000 mm**

SOURCES NOT INCLUDED

- Category: **LED RETROFIT**
- Number: **1**
- Socket: **GU10**

Stabligh "A" - Brown

Arik Levy



IP20   

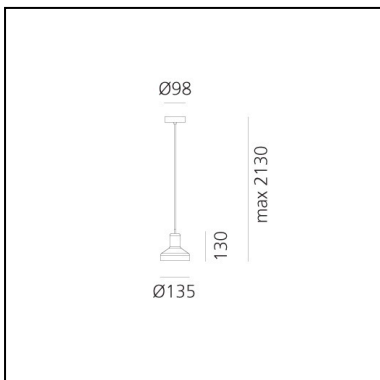

LUMINAIRE *

- Watt: **5,5W**
- Delivered lumen output: **340lm**
- Efficiency: **97%**
- Efficacy: **67.90lm/W**

* **CRi 90** data may vary depending on the source installed.
Light measurements are provided in relative form and technical lighting calculations may be updated according to the effective source used.

DESCRIPTION

The Stab light are produced with very traditional bohemian handblowing technology. Its handblowing to wooden moulds. The moulds are produced by hand as well, from hard and wet wood. The glass masters are using glass blowing pipe as basic instrument, gathering several layers of glass in various colors and by mouth blowing and shaping with hand tools prepares shape which is very close to the moulds shape. In final stage the glass masters puts the pre-shaped hot glass into the mould and finish the piece to the final shape, which is given by exact form of the mould. After the "hotshop" production phase the vases are finished on cutting shop, where additional parts are cutted out and surface is polished to high gloss. This production process stays on extraordinary skills of glass masters, who are passing their experience from generation to generation.

FEATURES

- Product Code: **DAL0027M80**
- Colour: **Brown**
- Installation: **Suspension**
- Material: **blown glass, metal**
- Series: **Design Collection**
- Environment: **Indoor**
- design by: **Arik Levy**

DIMENSIONS

- Height: **130 mm**
- Diameter: **135 mm**
- Base Diameter: **98 mm**
- Max Extension Height: **2000 mm**

SOURCES NOT INCLUDED

- Category: **LED RETROFIT**
- Number: **1**
- Socket: **GU10**

Stabligh "A" - Green amber

Arik Levy



IP20   

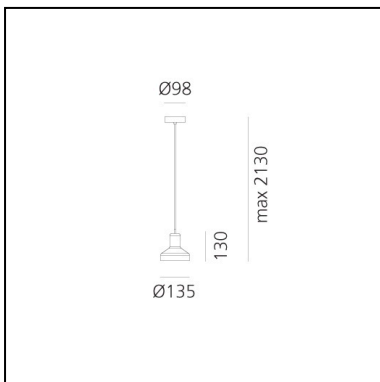

LUMINAIRE *

- Watt: **5,5W**
- Delivered lumen output: **340lm**
- Efficiency: **97%**
- Efficacy: **67.90lm/W**

* **CRi 90** data may vary depending on the source installed. Light measurements are provided in relative form and technical lighting calculations may be updated according to the effective source used.

DESCRIPTION

The Stab light are produced with very traditional bohemian handblowing technology. Its handblowing to wooden moulds. The moulds are produced by hand as well, from hard and wet wood. The glass masters are using glass blowing pipe as basic instrument, gathering several layers of glass in various colors and by mouth blowing and shaping with hand tools prepares shape which is very close to the moulds shape. In final stage the glass masters puts the pre-shaped hot glass into the mould and finish the piece to the final shape, which is given by exact form of the mould. After the "hotshop" production phase the vases are finished on cutting shop, where additional parts are cut out and surface is polished to high gloss. This production process stays on extraordinary skills of glass masters, who are passing their experience from generation to generation.

FEATURES

- Product Code: **DAL0027M12**
- Colour: **Green amber**
- Installation: **Suspension**
- Material: **blown glass, metal**
- Series: **Design Collection**
- Environment: **Indoor**
- design by: **Arik Levy**

DIMENSIONS

- Height: **130 mm**
- Diameter: **135 mm**
- Base Diameter: **98 mm**
- Max Extension Height: **2000 mm**

SOURCES NOT INCLUDED

- Category: **LED RETROFIT**
- Number: **1**
- Socket: **GU10**

Stabligh "B" - Aquamarine

Arik Levy



IP20   

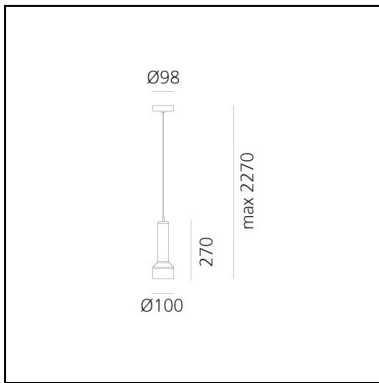

LUMINAIRE *

- Watt: **5,5W**
- Delivered lumen output: **340lm**
- Efficiency: **97%**
- Efficacy: **67.90lm/W**

* **CRi 90** data may vary depending on the source installed.
Light measurements are provided in relative form and technical lighting calculations may be updated according to the effective source used.

DESCRIPTION

The Stab light are produced with very traditional bohemian handblowing technology. Its handblowing to wooden moulds. The moulds are produced by hand as well, from hard and wet wood. The glass masters are using glass blowing pipe as basic instrument, gathering several layers of glass in various colors and by mouth blowing and shaping with hand tools prepares shape which is very close to the moulds shape. In final stage the glass masters puts the pre-shaped hot glass into the mould and finish the piece to the final shape, which is given by exact form of the mould. After the "hotshop" production phase the vases are finished on cutting shop, where additional parts are cut out and surface is polished to high gloss. This production process stays on extraordinary skills of glass masters, who are passing their experience from generation to generation.

FEATURES

- Product Code: **DAL0027N14**
- Colour: **Aquamarine**
- Installation: **Suspension**
- Material: **blown glass, metal**
- Series: **Design Collection**
- Environment: **Indoor**
- design by: **Arik Levy**

DIMENSIONS

- Height: **270 mm**
- Diameter: **100 mm**
- Base Diameter: **98 mm**
- Max Extension Height: **2000 mm**

SOURCES NOT INCLUDED

- Category: **LED RETROFIT**
- Number: **1**
- Socket: **GU10**

Stabligh "B" - Brown

Arik Levy



IP20   

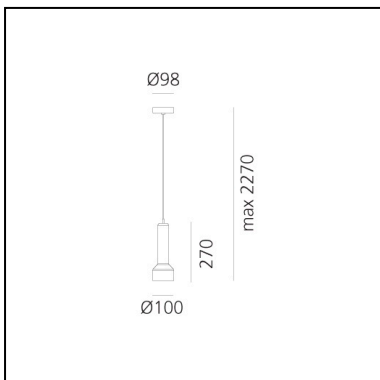

LUMINAIRE *

- Watt: **5,5W**
- Delivered lumen output: **340lm**
- Efficiency: **97%**
- Efficacy: **67.90lm/W**

* **CRi 90** data may vary depending on the source installed.
Light measurements are provided in relative form and technical lighting calculations may be updated according to the effective source used.

DESCRIPTION

The Stab light are produced with very traditional bohemian handblowing technology. Its handblowing to wooden moulds. The moulds are produced by hand as well, from hard and wet wood. The glass masters are using glass blowing pipe as basic instrument, gathering several layers of glass in various colors and by mouth blowing and shaping with hand tools prepares shape which is very close to the moulds shape. In final stage the glass masters puts the pre-shaped hot glass into the mould and finish the piece to the final shape, which is given by exact form of the mould. After the "hotshop" production phase the vases are finished on cutting shop, where additional parts are cutted out and surface is polished to high gloss. This production process stays on extraordinary skills of glass masters, who are passing their experience from generation to generation.

FEATURES

- Product Code: **DAL0027N80**
- Colour: **Brown**
- Installation: **Suspension**
- Material: **blown glass, metal**
- Series: **Design Collection**
- Environment: **Indoor**
- design by: **Arik Levy**

DIMENSIONS

- Height: **270 mm**
- Diameter: **100 mm**
- Base Diameter: **98 mm**
- Max Extension Height: **2000 mm**

SOURCES NOT INCLUDED

- Category: **LED RETROFIT**
- Number: **1**
- Socket: **GU10**

Stabligh "B" - Green amber

Arik Levy



IP20   

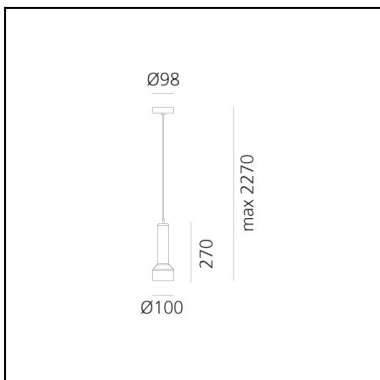

LUMINAIRE *

- Watt: **5,5W**
- Delivered lumen output: **340lm**
- Efficiency: **97%**
- Efficacy: **67.90lm/W**

* **CRi 90** data may vary depending on the source installed.
Light measurements are provided in relative form and technical lighting calculations may be updated according to the effective source used.

DESCRIPTION

The Stab light are produced with very traditional bohemian handblowing technology. Its handblowing to wooden moulds. The moulds are produced by hand as well, from hard and wet wood. The glass masters are using glass blowing pipe as basic instrument, gathering several layers of glass in various colors and by mouth blowing and shaping with hand tools prepares shape which is very close to the moulds shape. In final stage the glass masters puts the pre-shaped hot glass into the mould and finish the piece to the final shape, which is given by exact form of the mould. After the "hotshop" production phase the vases are finished on cutting shop, where additional parts are cutted out and surface is polished to high gloss. This production process stays on extraordinary skills of glass masters, who are passing their experience from generation to generation.

FEATURES

- Product Code: **DAL0027N12**
- Colour: **Green amber**
- Installation: **Suspension**
- Material: **blown glass, metal**
- Series: **Design Collection**
- Environment: **Indoor**
- design by: **Arik Levy**

DIMENSIONS

- Height: **270 mm**
- Diameter: **100 mm**
- Base Diameter: **98 mm**
- Max Extension Height: **2000 mm**

SOURCES NOT INCLUDED

- Category: **LED RETROFIT**
- Number: **1**
- Socket: **GU10**

Stabligh "C" - Aquamarine

Arik Levy



IP20   

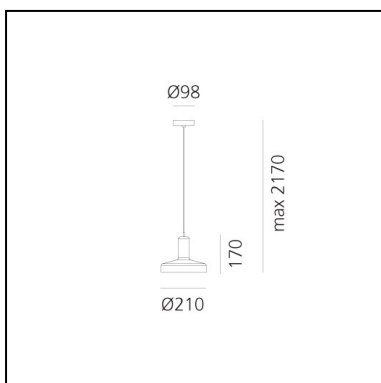

LUMINAIRE *

- Watt: **5,5W**
- Delivered lumen output: **340lm**
- Efficiency: **97%**
- Efficacy: **67.90lm/W**

* **CRi 90** data may vary depending on the source installed.
Light measurements are provided in relative form and technical lighting calculations may be updated according to the effective source used.

DESCRIPTION

The Stab light are produced with very traditional bohemian handblowing technology. Its handblowing to wooden moulds. The moulds are produced by hand as well, from hard and wet wood. The glass masters are using glass blowing pipe as basic instrument, gathering several layers of glass in various colors and by mouth blowing and shaping with hand tools prepares shape which is very close to the moulds shape. In final stage the glass masters puts the pre-shaped hot glass into the mould and finish the piece to the final shape, which is given by exact form of the mould. After the "hotshop" production phase the vases are finished on cutting shop, where additional parts are cutted out and surface is polished to high gloss. This production process stays on extraordinary skills of glass masters, who are passing their experience from generation to generation.

FEATURES

- Product Code: **DAL0027014**
- Colour: **Aquamarine**
- Installation: **Suspension**
- Material: **blown glass, metal**
- Series: **Design Collection**
- Environment: **Indoor**
- design by: **Arik Levy**

DIMENSIONS

- Height: **170 mm**
- Diameter: **210 mm**
- Base Diameter: **98 mm**
- Max Extension Height: **2000 mm**

SOURCES NOT INCLUDED

- Category: **LED RETROFIT**
- Number: **1**
- Socket: **GU10**

Stabligh "C" - Brown

Arik Levy



IP20   

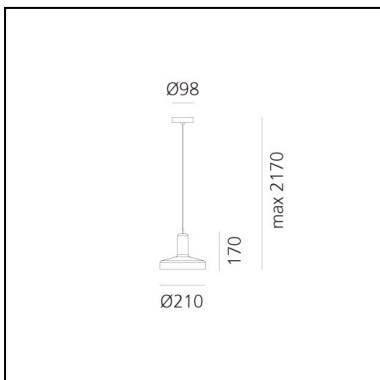

LUMINAIRE *

- Watt: **5,5W**
- Delivered lumen output: **340lm**
- Efficiency: **97%**
- Efficacy: **67.90lm/W**

* **CRi 90** data may vary depending on the source installed.
Light measurements are provided in relative form and technical lighting calculations may be updated according to the effective source used.

DESCRIPTION

The Stab light are produced with very traditional bohemian handblowing technology. Its handblowing to wooden moulds. The moulds are produced by hand as well, from hard and wet wood. The glass masters are using glass blowing pipe as basic instrument, gathering several layers of glass in various colors and by mouth blowing and shaping with hand tools prepares shape which is very close to the moulds shape. In final stage the glass masters puts the pre-shaped hot glass into the mould and finish the piece to the final shape, which is given by exact form of the mould. After the "hotshop" production phase the vases are finished on cutting shop, where additional parts are cutted out and surface is polished to high gloss. This production process stays on extraordinary skills of glass masters, who are passing their experience from generation to generation.

FEATURES

- Product Code: **DAL0027080**
- Colour: **Brown**
- Installation: **Suspension**
- Material: **blown glass, metal**
- Series: **Design Collection**
- Environment: **Indoor**
- design by: **Arik Levy**

DIMENSIONS

- Height: **170 mm**
- Diameter: **210 mm**
- Base Diameter: **98 mm**
- Max Extension Height: **2000 mm**

SOURCES NOT INCLUDED

- Category: **LED RETROFIT**
- Number: **1**
- Socket: **GU10**

Stabligh "C" - Green amber

Arik Levy



IP20   

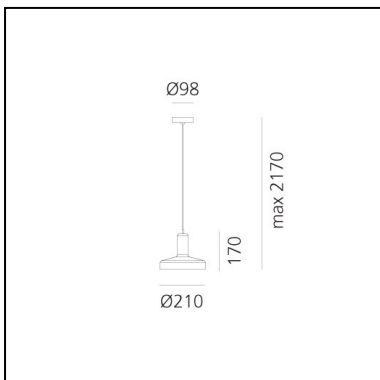

LUMINAIRE *

- Watt: **5,5W**
- Delivered lumen output: **340lm**
- Efficiency: **97%**
- Efficacy: **67.90lm/W**

* **CRi 90** data may vary depending on the source installed. Light measurements are provided in relative form and technical lighting calculations may be updated according to the effective source used.

DESCRIPTION

The Stab light are produced with very traditional bohemian handblowing technology. Its handblowing to wooden moulds. The moulds are produced by hand as well, from hard and wet wood. The glass masters are using glass blowing pipe as basic instrument, gathering several layers of glass in various colors and by mouth blowing and shaping with hand tools prepares shape which is very close to the moulds shape. In final stage the glass masters puts the pre-shaped hot glass into the mould and finish the piece to the final shape, which is given by exact form of the mould. After the "hotshop" production phase the vases are finished on cutting shop, where additional parts are cutted out and surface is polished to high gloss. This production process stays on extraordinary skills of glass masters, who are passing their experience from generation to generation.

FEATURES

- Product Code: **DAL0027012**
- Colour: **Green amber**
- Installation: **Suspension**
- Material: **blown glass, metal**
- Series: **Design Collection**
- Environment: **Indoor**
- design by: **Arik Levy**

DIMENSIONS

- Height: **170 mm**
- Diameter: **210 mm**
- Base Diameter: **98 mm**
- Max Extension Height: **2000 mm**

SOURCES NOT INCLUDED

- Category: **LED RETROFIT**
- Number: **1**
- Socket: **GU10**