

# Vitruvio - Floor

Atelier Oi

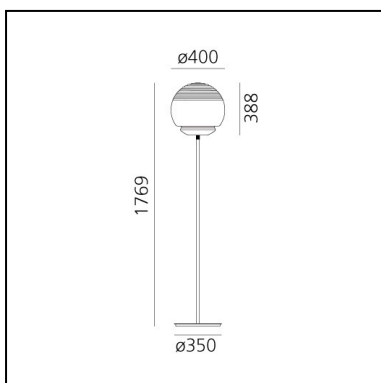

## LUMINAIRE \*

- Watt: **21W**
- Delivered lumen output: **2202lm**
- Efficiency: **90%**
- Efficacy: **104.87lm/W**
- CRI: **80**

\* Photometric data may vary depending on the source installed.  
Light measurements are provided in relative form and technical lighting calculations may be updated according to the effective source used.

## Notes

## DESCRIPTION

A family of appliances where mechanical intelligence turns into an expression of beauty. A thin frame and a blown-glass diffuser are the main features of this project.

*“These two opposite elements – a thin supporting one and a soft one working as an encompassing cocoon – are perfectly integrated.”*

### Atelier Oi

Three metal rods are introduced into the sphere by means of an ingenious mechanism inspired by the clockmaking art, thus creating the frame that supports the glass globe. The mobile rods open up inside the diffuser and, as a result of the utmost precision of the geometric joints and of balanced weights, support the glass sphere, both when turned upwards in the table and floor versions, and when turned downwards in the suspension version.

Function and look perfectly match also in the diffuser. The transparent glass is blown into a shape that derives from optical intelligence. The embossed horizontal stripes conceal the source from view, mitigate glaring, and ensure more even light diffusion. The appliance combines tradition and innovation, the old savoir-faire of the glass-blowing art approached with a future-oriented technological outlook.

The projects of Atelier Oi are always pervaded with intelligence, quality, emotion, poetry and, particularly, respect for such values as sustainability, ethical responsibility, and manufacturing responsibility, which are paramount to Artemide.

The glass and the frame are two free elements, joined together by a simple, easily reversible mechanical device; the optical system generates a comfortable high-efficiency light, the diffuser is obtained by means of a single manufacturing process, all manufacturing and maintenance features are calibrated to obtain a perfectly sustainable product.

Also featured in this project, elegance, poetry, and ethics are distinctive traits of the work of Atelier Oi, capable to combine and merge materials, visions, and technologies into a “form” that is the exact consequence of all these aspects, and to convey great emotion in doing so.

## FEATURES

- Product Code: **1262010A**
- Colour: **Brass**
- Installation: **Floor**
- Material: **Brass, Glass**
- Series: **Design Collection**
- design by: **Atelier Oi**

## DIMENSIONS

- Height: **1769 mm**
- Diameter: **400 mm**
- Base Diameter: **350 mm**

**SOURCES NOT INCLUDED**

- Category: **LED RETROFIT**
- Number: **1**
- Socket: **E27**

# Vitruvio - Floor - Black

Atelier Oi

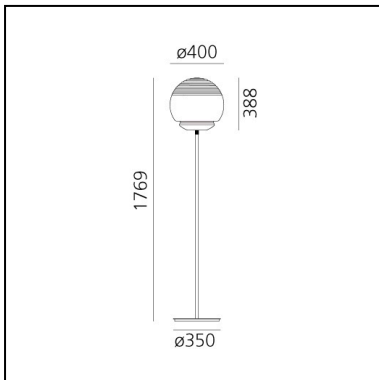

## LUMINAIRE \*

- Watt: **21W**
- Delivered lumen output: **1399lm**
- Efficiency: **57%**
- Efficacy: **66.60lm/W**
- CRI: **80**

\* Photometric data may vary depending on the source installed. Light measurements are provided in relative form and technical lighting calculations may be updated according to the effective source used.

## Notes

## DESCRIPTION

A family of appliances where mechanical intelligence turns into an expression of beauty. A thin frame and a blown-glass diffuser are the main features of this project.

*“These two opposite elements – a thin supporting one and a soft one working as an encompassing cocoon – are perfectly integrated.”*

### Atelier Oi

Three metal rods are introduced into the sphere by means of an ingenious mechanism inspired by the clockmaking art, thus creating the frame that supports the glass globe. The mobile rods open up inside the diffuser and, as a result of the utmost precision of the geometric joints and of balanced weights, support the glass sphere, both when turned upwards in the table and floor versions, and when turned downwards in the suspension version.

Function and look perfectly match also in the diffuser. The transparent glass is blown into a shape that derives from optical intelligence. The embossed horizontal stripes conceal the source from view, mitigate glaring, and ensure more even light diffusion. The appliance combines tradition and innovation, the old savoir-faire of the glass-blowing art approached with a future-oriented technological outlook.

The projects of Atelier Oi are always pervaded with intelligence, quality, emotion, poetry and, particularly, respect for such values as sustainability, ethical responsibility, and manufacturing responsibility, which are paramount to Artemide.

The glass and the frame are two free elements, joined together by a simple, easily reversible mechanical device; the optical system generates a comfortable high-efficiency light, the diffuser is obtained by means of a single manufacturing process, all manufacturing and maintenance features are calibrated to obtain a perfectly sustainable product.

Also featured in this project, elegance, poetry, and ethics are distinctive traits of the work of Atelier Oi, capable to combine and merge materials, visions, and technologies into a “form” that is the exact consequence of all these aspects, and to convey great emotion in doing so.

## FEATURES

- Product Code: **1262030A**
- Colour: **Black**
- Installation: **Floor**
- Material: **Brass, Glass**
- Series: **Design Collection**
- design by: **Atelier Oi**

## DIMENSIONS

- Height: **1769 mm**
- Diameter: **400 mm**
- Base Diameter: **350 mm**

**SOURCES NOT INCLUDED**

- Category: **LED RETROFIT**
- Number: **1**
- Socket: **E27**